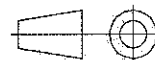
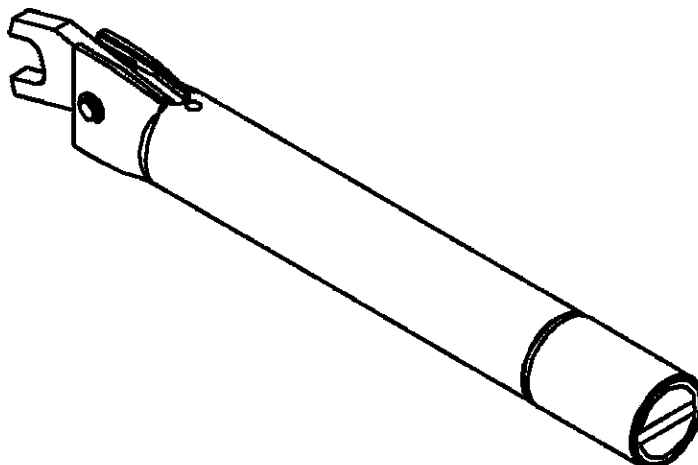
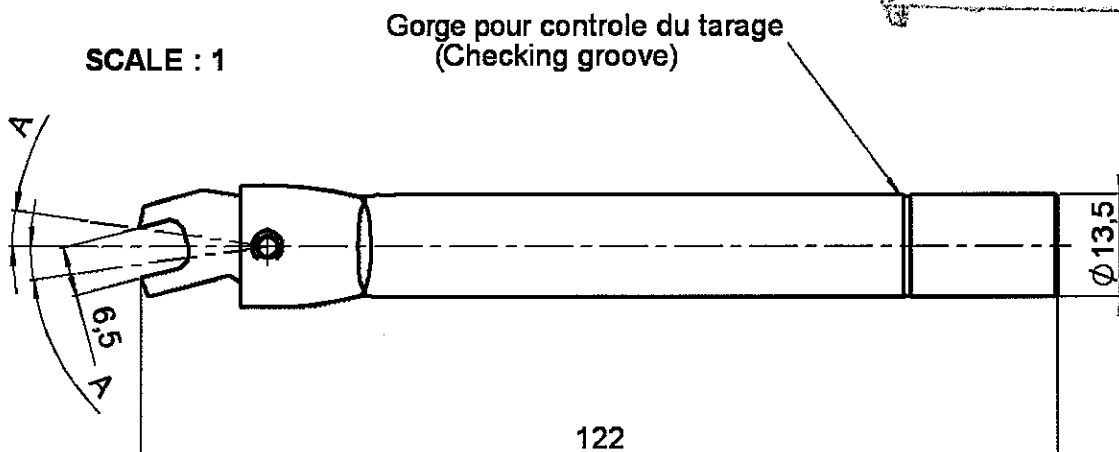

TORQUE WRENCH

6.5 MM - 80 to 120 N.cm

R282.323.000

Series : OUT

ORIGINAL**OPERATION**

The torque wrench is designed to automatically make a « click sound ».

The wrench will work the same in both directions.

Be careful : DO NOT APPLY PRESSURE to the wrench AFTER hearing the click sound, it will possibly damage the connector.

ENSURE PROPER TORQUE

Apply verification force at the groove level on the handle .

- torque wrench 100 Ncm +/-20 Ncm
- A A' torque wrench angle about 8°

Issue : 0538 B

In the effort to improve our products, we reserve the right to make changes judged to be necessary.

**RADIALL®**